



Network DSP POWER AMPLIFIER

PD 700/PD 700 Dante



User manual

MENU

Chapter 1 Introduction	- 1 -
Chapter 2 Technical parameters	- 2 -
Chapter 3 Functions structure	- 3 -
Chapter 4 Operation of control software - Mconsole	- 7 -
4.1 Operating condition	- 7 -
4.2 Connections setting	- 8 -
4.3 DSP functions setting	- 10 -
4.3.1 DSP functions setting - INPUT (Support Dante/Analog backup)	- 11 -
4.3.2 DSP functions setting - NOISE GATE	- 12 -
4.3.3 DSP functions setting - PEQ-X (input and output)	- 12 -
4.3.4 DSP functions setting - DELAY (input and output)	- 13 -
4.3.5 DSP functions setting - MATRIX MIX	- 14 -
4.3.6 DSP functions setting - COMPRESSOR	- 15 -
4.3.7 DSP functions setting - LIMITER	- 15 -
4.3.8 DSP functions setting - OUTPUT	- 15 -
4.4 Monitoring and setting of channels	- 16 -
4.5 Menu - File	- 17 -
4.6 Menu - Device	- 18 -
4.7 Menu - Connection	- 19 -
4.8 Menu - Preset	- 19 -
4.9 Menu - System	- 20 -
4.10 FIR filter and function	- 20 -
4.10.1 FIR filter and applications	- 20 -
4.10.2 Using FIR DESIGNER in Mconsole to adjust FIR magnitude and phase	- 22 -
4.10.2.a FIR DESIGNER - Import	- 23 -
4.10.2.b FIR DESIGNER - FIR-EQ	- 24 -
4.10.2.c FIR DESIGNER - Magnitude Correction and Phase Correction	- 24 -
4.10.2.d FIR DESIGNER - Generate	- 25 -

Chapter 1 Introduction

NPA46A/NPA46AD is a 4in4out network DSP power amplifier, integrated with DSP process, IPS colourful display and other powerful function. This power amplifier support a variety of input methods: analog\Dante network. User can select each analog or Dante signal with its priority, which realize signal backup function. Support constant resistance 8Ω \(4Ω) and constant voltage 100V\70V. Standard FIR automatic linear magnitude and phase function provide user a powerful setting method to speakers.

User can monitor power, current, voltage, temperature and impedance from display in real time. With RJ45\USB and common series connectors, PC software Mconsole provides user a easy way to control multiple devices, identify device, remotely turn on/off and set DSP function. RS232/RS485/GPIO connectors support device being controlled from third-party system.

Applications

- Sports stadium
- Colleges and universities
- Meeting Room
- Shopping mall
- Hotel
- Airport terminal

Features

- Dante network audio in option and Dante-Analog backup function
- Built-in DSP process
- FIR automatic linear magnitude and phase
- Remote on \ standby, call amplifier
- Support 100V \ 70V \ 8Ω \ 4Ω
- Free setting to limit power and voltage
- IPS colorful display
- Monitoring temperature \ power \ voltage \ current \ resistance

Chapter 2 Technical parameters

Product	PD 700/PD 700 Dante	
Amplifier channels	4	
Output power	4Ω	8Ω
	1000watts	700watts
	bridge 2*2000watts	
100V output power	bridge model, 100V(2*max 1250W)	
70V output power	bridge model, 70V(2*max 612.5W)	
Max. output voltage	69V	
Max. output current	15A	
Min. load output	4Ω/channel	
Input connector	4*XLR	
Output connector	4*SpeakOn	
Max. input level	12dBu sensitivity (17dBu, 5.484V)	
	6dBu sensitivity (17dBu, 5.484V)	
	0dBu sensitivity (17dBu, 5.484V)	
Sensitivity	12dBu sensitivity (27dB)	
	6dBu sensitivity (33dB)	
	0dBu sensitivity (39dB)	
SNR	12dBu sensitivity (103dB)	
	6dBu sensitivity (98dB)	
	0dBu sensitivity (93dB)	
Frequency response	20Hz to 20kHz (±0.5dB) @1W, 8Ω	
THD+N	<1%@1W, 8Ω	
Sampling	48k / 24bit	
Dante in option	4 input channels	
Display	320*240 IPS colourful display	
Protections	DSP limiter, high temperature, DC, high frequency, short circuit, back EMF, peak current limiter, Back EMF, Surge current limiter, startup delay, power circuit breaker protection, power over voltage/under voltage protection	
PC control software	Mconsole	
Power requirement	VAC100~240 50/60Hz	
Device	Net weight 5.6kg, 483mm*309mm*44.5mm	
Package	Gross weight 6.2kg, 520mm*442mm*90mm	

Chapter 3 Functions structure

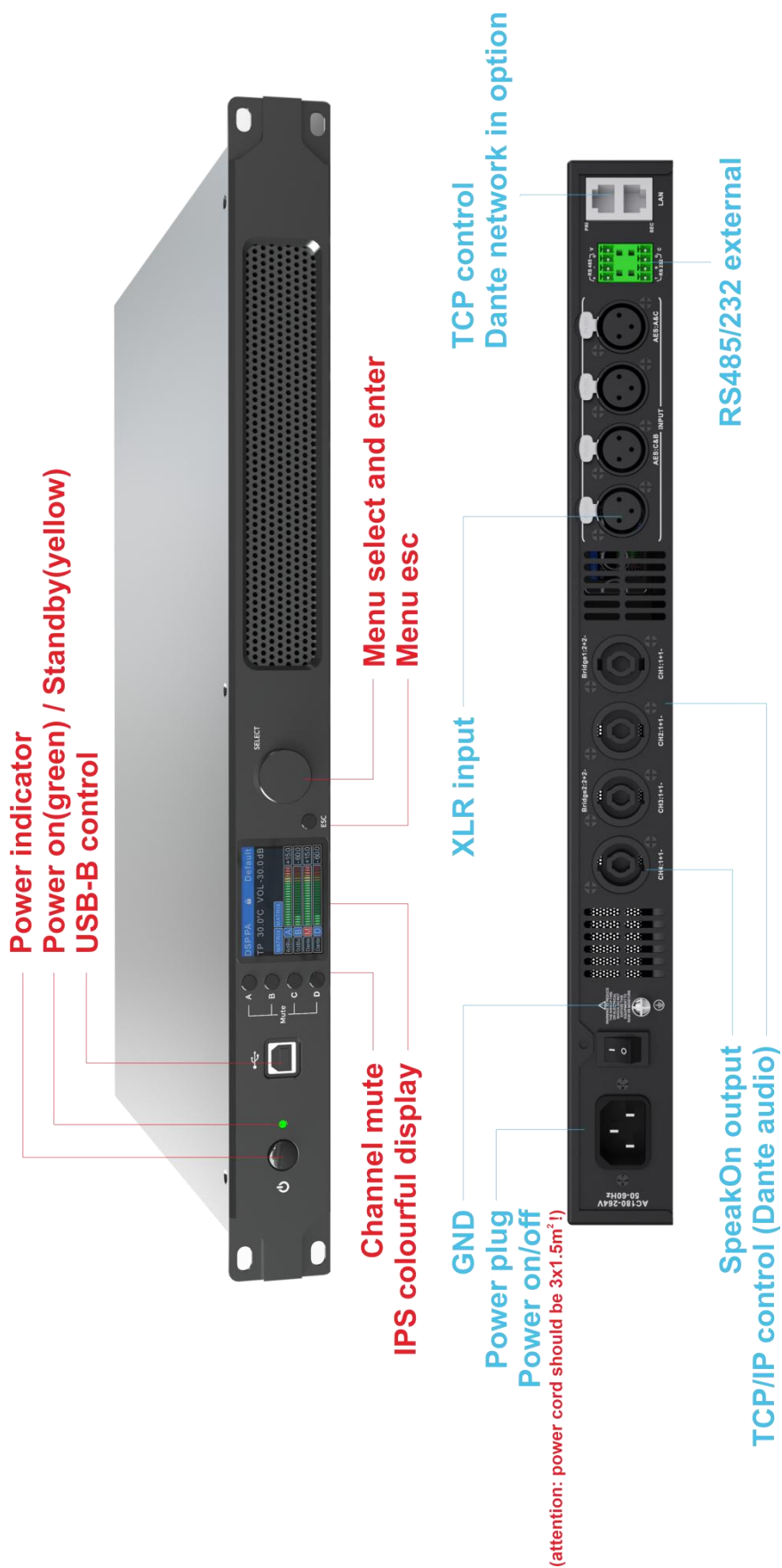

NETWORK DSP POWER AMPLIFIER

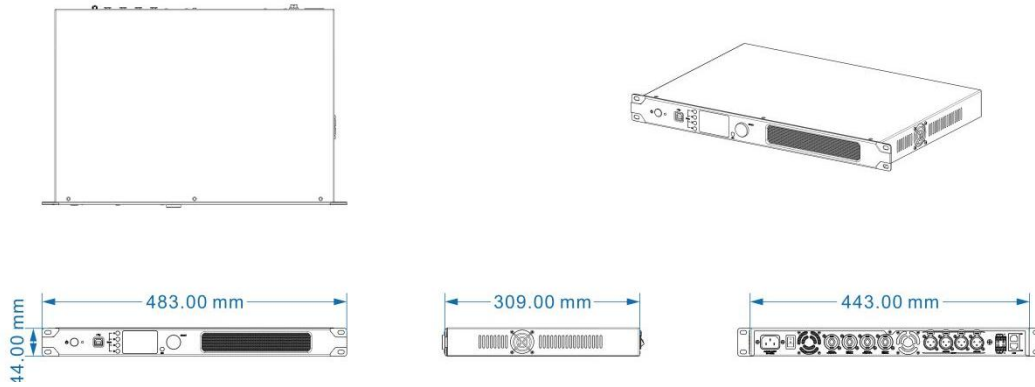

Description of display

Long press "Enter" 2 second to unlock

Main page

Device name	Device Default	Current preset
Temperature	TP 30.0°C VOL -30.0 dB	Device volume
Mute status	MATRIX MATRIX	Channels gain
	6dBu A +15.0	
	0dBu B -60.0	
	Dante M +15.0	
	Dante D -60.0	
	Gain level	

PC control

Limiter status	Device Default	Device Default
	TP 30.0°C VOL -30.0 dB	TP 30.0°C VOL -30.0 dB
	PC control	PC control
	MATRIX MATRIX	MATRIX MATRIX
	6dBu A +15	CLIP A LIM
	0dBu B -60	0dBu B -60.0
	Dante M +15	CLIP M +15.0
	Dante D -60	Dante D -60.0



Menu

Volume

Channels
Mute

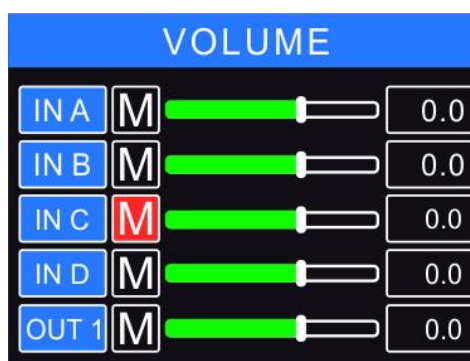

Channels gain

Presets



Source

Input
Analog
Dante



Sensitivity
0dBu
6dBu

Status

STATUS

S STEREO **B** BRIDGE
P PARALLEL **M** MATRIX

A **B** **C** **D** — **M** — CH1
A **B** **C** **D** — **M** — CH2
A **B** **C** **D** — **M** — CH3
A **B** **C** **D** — **M** — CH4

STATUS

S STEREO **B** BRIDGE
P PARALLEL **M** MATRIX

A **B** **C** **D** — **S** — CH1
A **B** **C** **D** — **S** — CH2
A **B** **C** **D** — **M** — CH3
A **B** **C** **D** — **M** — CH4

STATUS

S STEREO **B** BRIDGE
P PARALLEL **M** MATRIX

A **B** **C** **D** — **P** — CH1
A **B** **C** **D** — **P** — CH2
A **B** **C** **D** — **M** — CH3
A **B** **C** **D** — **M** — CH4

STATUS

S STEREO **B** BRIDGE
P PARALLEL **M** MATRIX

A **B** **C** **D** — **B** — CH1 ++
A **B** **C** **D** — **B** — CH2 +- 
A **B** **C** **D** — **M** — CH3
A **B** **C** **D** — **M** — CH4

Chapter 4 Operation of control software - Mconsole

Mconsole provides user with a fast interaction to control one or more devices through multiple methods: TCP/IP, USB, common serial port (RS232/485). Easily set DSP functions of device, GPIO control and check central control codes. The configuration parameter can be stored in presets, convenient for various applications.

4.1 Operating condition

Mconsole is suitable for Win7/8/10/11 x86/x64 PC system with Microsoft .NET Framework 4.0. When connecting device in USB method, the device will automatically ejects the storage disk, user can unzip software in Windows, no need to setup.

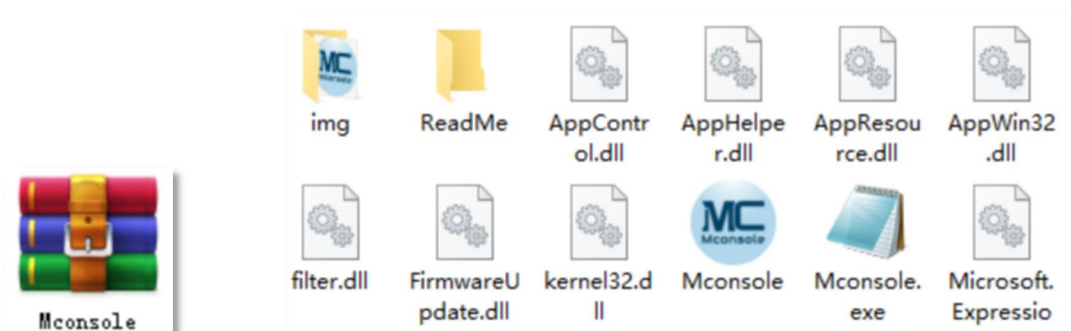

Double click **Mconsole.exe**, the main interface will pop up.

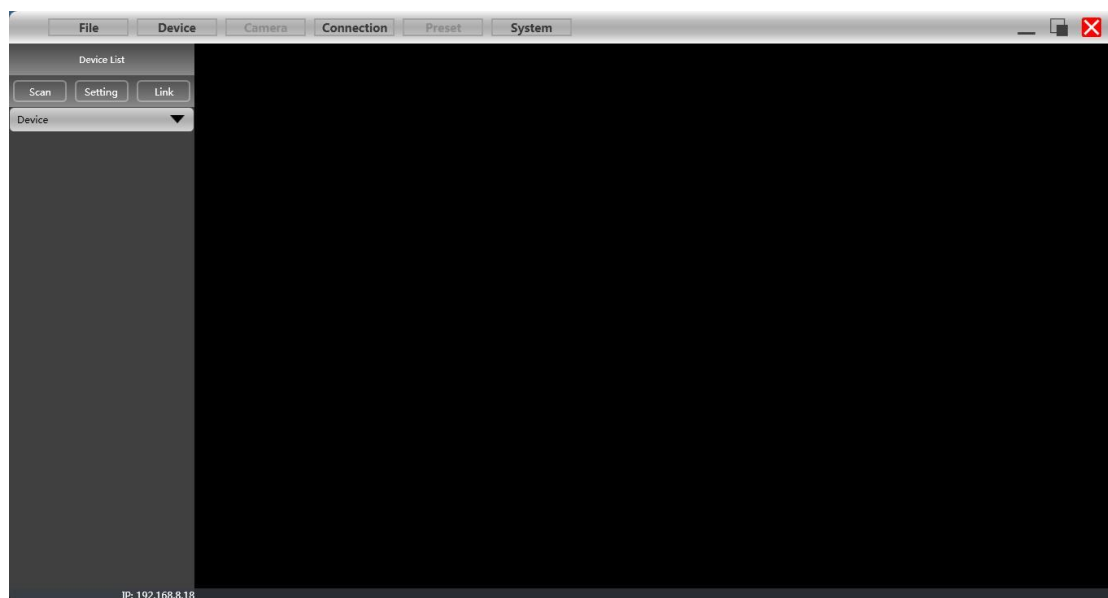

4.2 Connections setting

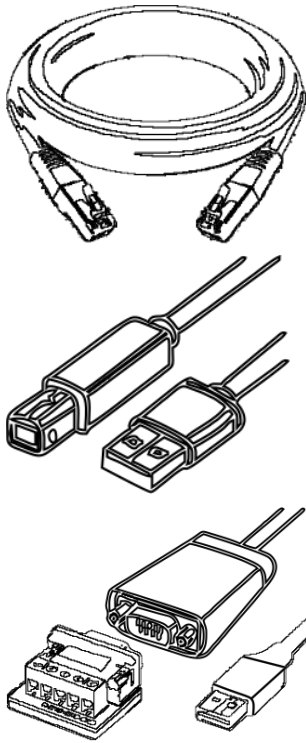

If connect device by using network cable, click **Setting** in Device List, choose **TCP** in Connection windows.



If connect device by using USB A-B, click **Setting** in Device List, choose **USB** in Connection windows.



If connect device by using network cable, click **Setting** in Device List, choose **COM** in Connection windows. Please check port and baud rate carefully for 232 or 485 before setting.

The software will scan device the method set in last time, to check if device is connected. If successfully connected, devices will be shown in device list.



User can mute device, refresh connecting, or delete device in this window. Single click device, to load function interface.



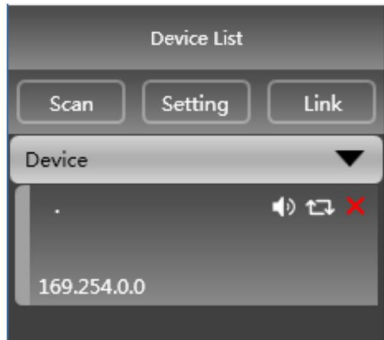

When using TCP control, there is a situation that only one point is displayed after scanning, but can not connect device. In this case, user need to change the IP address of the device to the same network segment as the PC computer.



Right-click the device enclosure, a Net Setting window will show.

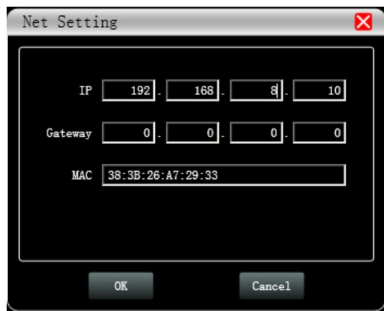

Set IP address of device refer to IP showed in the bottom of the software.

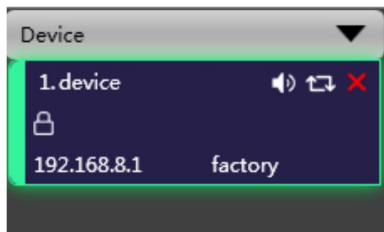

Successfully scanned and connected.

User can link multiple same devices in group by clicking Link button, and then set group device, group name and main device, link mode and parameter according to needs.

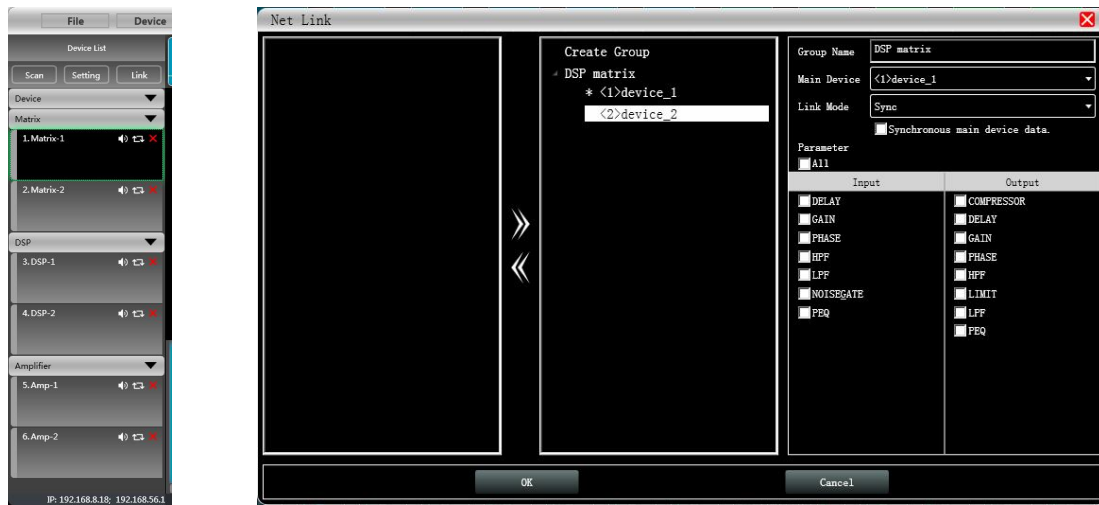

4.3 DSP functions setting



Double-click HOME icon to open all functional interfaces, or double-click a function icon separately to open the corresponding interface. When multiple function windows opened, users can drag the window to switch function Settings.

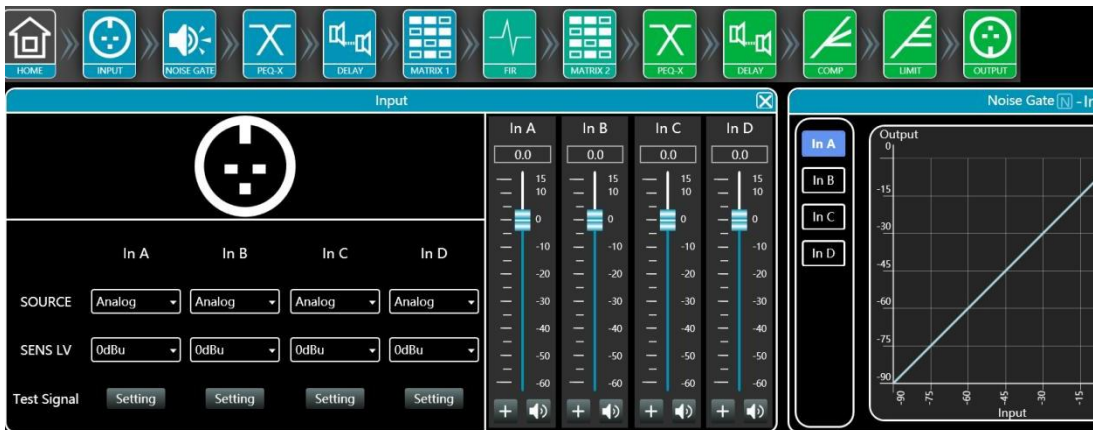

4.3.1 DSP functions setting - INPUT (Support Dante/Analog backup)

- Set source of each channel;
- Set sensitivity of each channel 0/6dBu;
- Set gains, phase or mute in each channel;
- When choosing test signal, user can select Sine/Pink Noise/White Noise for each input channel.

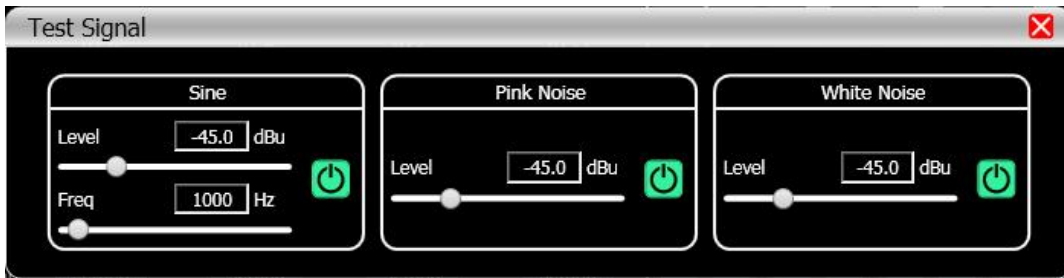
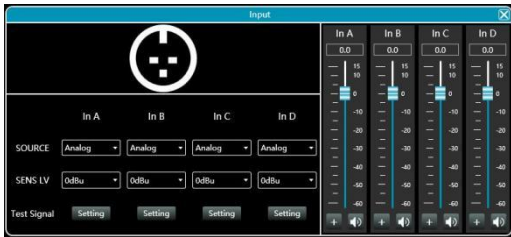

Dante and analog signal backup

1. Connect both analog and Dante signal input interface, and select AnalogPri as source, analog signal would be in priority for using. In events of disconnecting analog source, the amplifier would switch Dante signal automatically.



2. Connect both analog and Dante signal input interface, and select DantePri as source, Dante signal would be in priority for using. In events of disconnecting Dante source, the amplifier would switch analog signal automatically.

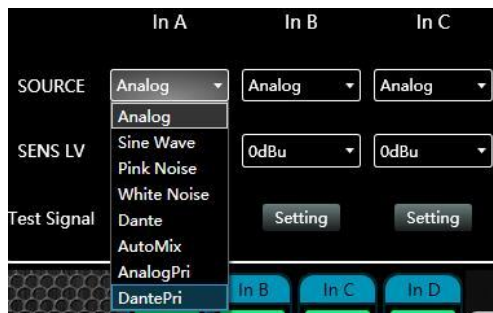

Remark: Backup mode only supports analog signals and Dante signals with the same audio (pause during playback is the same).

4.3.2 DSP functions setting - NOISE GATE

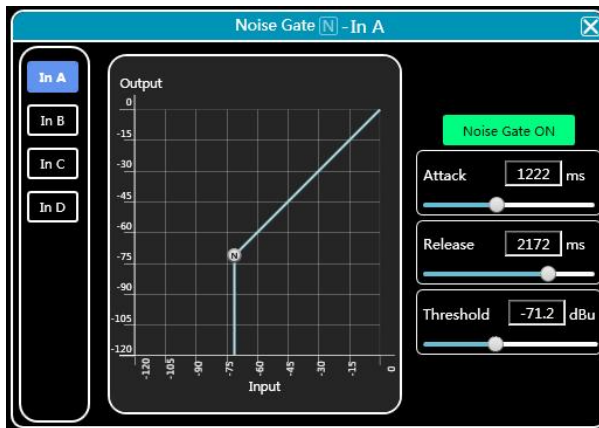

- Attack: 1 to 2895ms;
- Release: 1 to 2895ms;
- Threshold: -120 to 0dBu;
- Click **Noise Gate ON** to enable this function.

4.3.3 DSP functions setting - PEQ-X (input and output)



High pass filter



enter value of frequency and select type, press **ON** to enable this function:
Butterworth 6/12/18/24/36/48, Bessel 12/24/36/48, Linkwitz-Riley 12/24/36/48.

Low pass filter



enter value of frequency and select type, press **ON** to enable this function:
Butterworth 6/12/18/24/36/48, Bessel 12/24/36/48, Linkwitz-Riley 12/24/36/48.

PEQ 15 bands for input channel

Type: PEQ/LSLV/HSLV/ALLPASS-1/ALLPASS-2;

Freq(Hz) Q Gain(dB): input value or use mouse pulley to set value;

Users can also drag the frequency dot on the curve to adjust.

PEQ 10 bands for output channel

Type: PEQ/**LSLV**/**HSLV**/**ALLPASS-1**/**ALLPASS-2**;

Freq(Hz) Q Gain(dB): input value or use mouse pulley to set value;

Users can also drag the frequency dot on the curve to adjust.

Phase curve: display the phase curve of the current channel.

View: show or hide all balance control points.

Bypass: turn on or off all equalizer EQ of the current channel at the same time



Preset: save all the setting parameter of the equalizer of the current channel to the computer, and recall the channel equalizer parameter of the computer, which can be called across channels and devices.

Copy: copy the current channel equalizer parameter value, which can be pasted to other similar channels (such as input channel parameter can only be copied to other input channels).

Paste: used in combination with the copy button to paste the last copied equalizer parameter value to the current channel.



Reset: reset the equalizer parameter to the default parameter values.

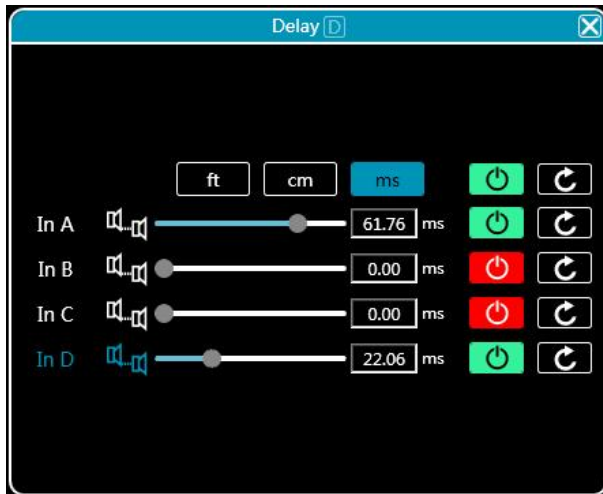

As shown in the figure above, the left side  is the interface switching button for each channel. Click to switch the EQ channel, and the color is the currently selected channel.  is the curve color of the EQ channel.  For each channel's EQ curve display switch, check it to enable it to display the curves of other channels in the current channel interface.

4.3.4 DSP functions setting - DELAY (input and output)



- Max 100ms for input channel;
- Max 20ms for output channel;
- Click  to enable this function;
- Click  to reset each channel;
- User can switch ft/cm/ms measurement for delay.

4.3.5 DSP functions setting - MATRIX MIX

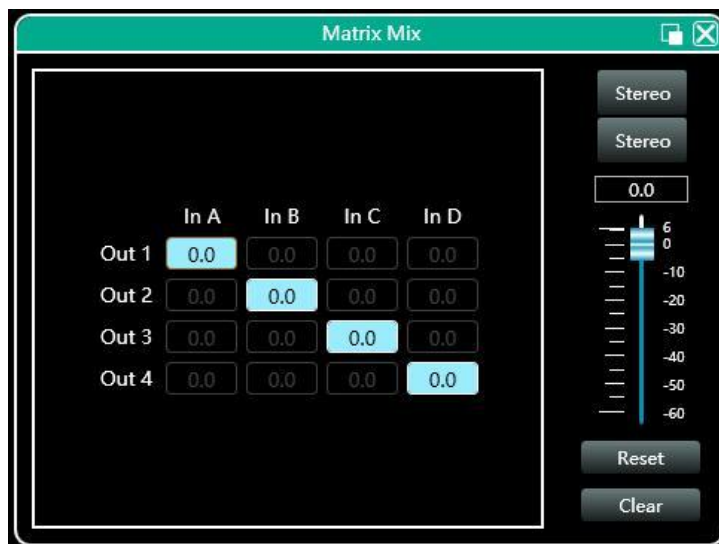

In the above figure, input channel (on top side) corresponds to output channel. The value box with a value is mixing key of channels. When the mixing key is green (double-click the value box to switch the state), the input channel and output channel signal realizes the mixing function.

The right part of the above figure contains the gain, reset button, and clear button of the matrix mix. Click the value box on the left, and then drag the sliding block of the matrix mix gain or enter a value in the value box to adjust the matrix block. Click the reset button to reset the matrix mixing function to the initial one-to-one state; click the clear button to clear all the matrix mixing functions, and there is no correspondence between the input and output of the device.

4.3.6 DSP functions setting - COMPRESSOR

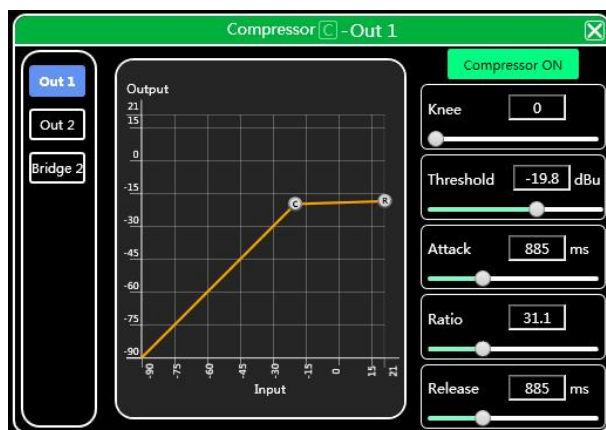

- Soft knee: 0 to 30;
- Threshold: -90 to 21 dB;
- Attack: 1 to 2895 ms;
- Ratio: 1 to 100;
- Release: 1 to 2895 ms;
- Click **Compressor ON** to enable this function;

4.3.7 DSP functions setting - LIMITER

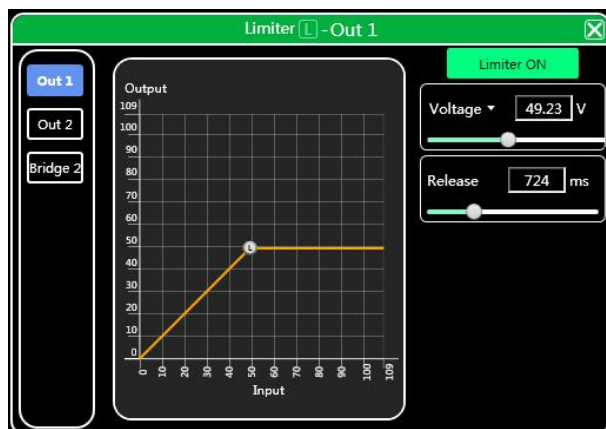

- Voltage: 0.01 to 42.43V;
- Power: 0.01 to 450watts;
- Release: 1 to 2895 ms;
- Click **Limiter ON** to enable this function;

4.3.8 DSP functions setting - OUTPUT

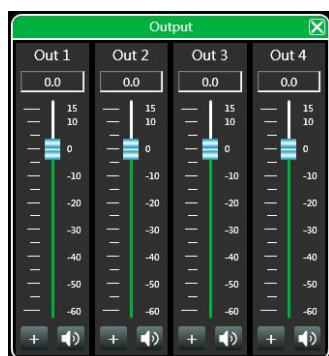

- Set phase of signal;
- Set mute of output channel;
- Set gain of output channel;
- M.Vol is used for setting total volume for device.

4.4 Monitoring and setting of channels

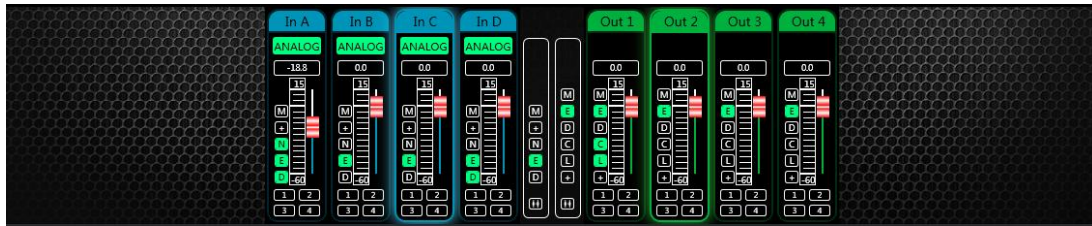

User can monitor gains level of input and output channels.

4.4.1 Channel gain level

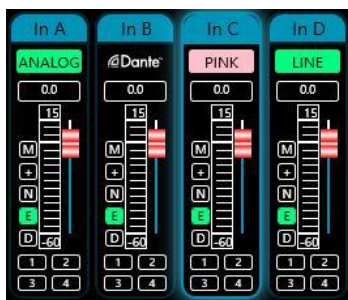

There are 3 kinds of input signal in some products: ANALOG, DANTE network audio, testing signal and AutoMix (analog and Dante). It will show a label for user.

Input value, drag gain fader or use mouse pulley to set value of gain.

4.4.2 Quick buttons of DSP in channels



- M Mute
- + Phase
- N Noise Gate
- E PEQ
- D Delay

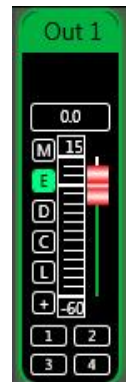

- M Mute
- E PEQ
- D Delay
- C Compressor
- L Limiter
- + Phase

4.4.3 Group and channels link

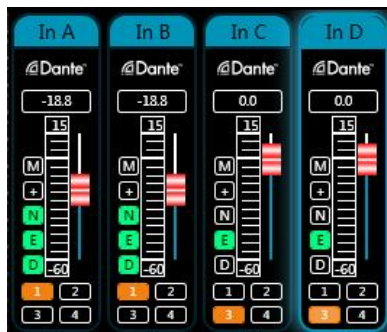

User can quickly set channels in groups for opening or closing mute, phase, noise gate, PEQ and delay function.

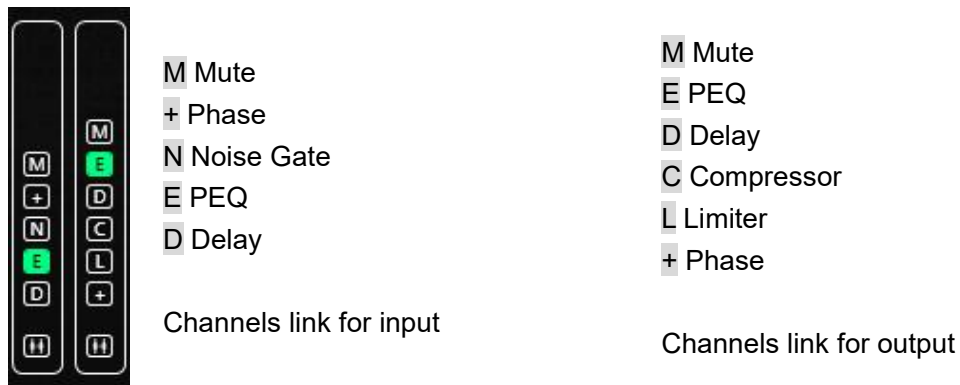

When click link button, Channels Link window would show as below:

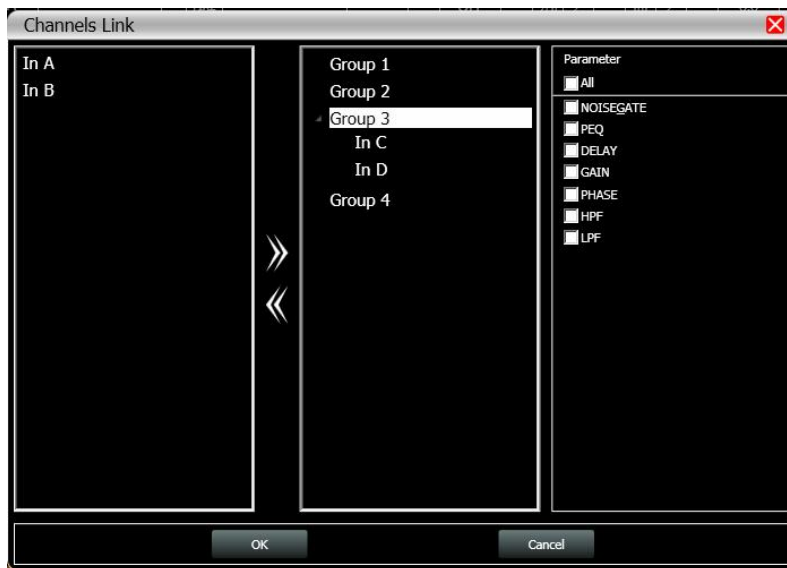

Select the corresponding channels to link, they will be in group for user to set parameter.

4.5 Menu - File

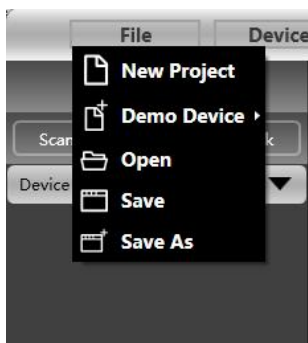

New project: the project is restored to the initial open state.

Demo Device: user can view all the functions of the device without affecting the specific device connected.

Open: open an existing device management project from the computer disk.

Save: save the current equipment management project in the computer disk.

Save as: save the current equipment management project to the computer disk.

4.6 Menu - Device

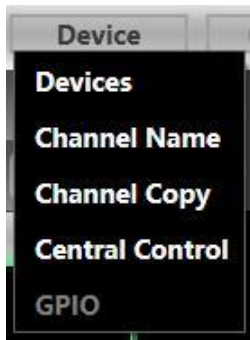

Devices: view or modify the software version information, device name and device IP address of the upper and lower computer of the device. Set password of device.

Channel name: set the name of each input and output channel, with memory function.

Channel copy: copy device input and output channel parameter, can realize cross-device copy parameter (Note: the same type of device is required).

Central control and GPIO: provides user a quickly way to inquiry code of Center Control and GPIO setting. More details, please refer to another user manual <GPIO And Center Control Code User Manual>, it provides whole guide and codes for user to match every specific system.

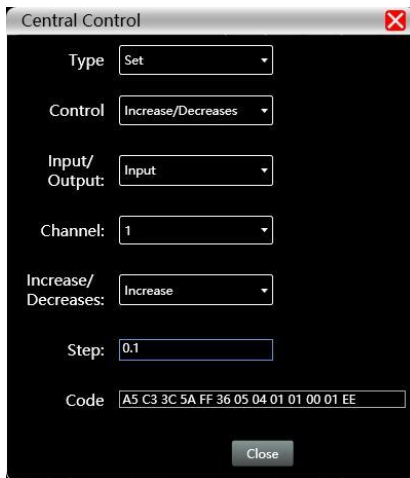

4.7 Menu - Connection

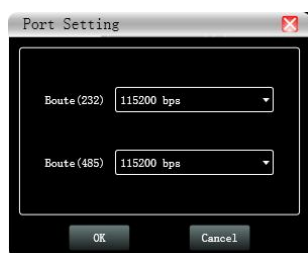

Port: set the connection mode, port number and baud rate, confirm the connection mode and then select the corresponding port.

Connect: connect and download the device parameter.

Disconnect: disconnect the connected device.

Connect all: connect and download the device parameter of all devices in the device list.

Disconnect all: disconnect all connected devices in the device list.

4.8 Menu - Preset

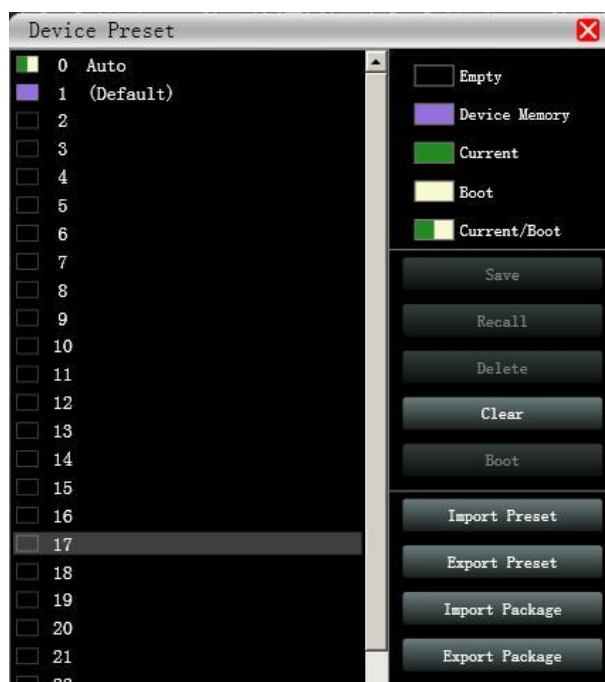

Save: select the saved gear, save all the parameter of the current automatic gear of the machine to the device preset (2~30 Preset bit).

Recall: call the device preset to the current automatic gear position.

Delete: delete the existing preset, the default file cannot be deleted, over written or saved.

Clear: delete all presets in the device.

Boot: select a certain preset, after setting it as the boot file, each time the device is powered on, it will automatically call the save the parameter; the last set parameter need to be automatically saved, please set the automatic file to the boot file.

Import preset: import a single preset file on the computer.

Export the preset: export all the parameter of the current state to the computer, and generate a single preset file.

Import preset package: import the preset package file containing multiple presets on the computer.

Export preset package: pack multiple presets in the machine's preset into one preset package and export it to the computer.

4.9 Menu - System

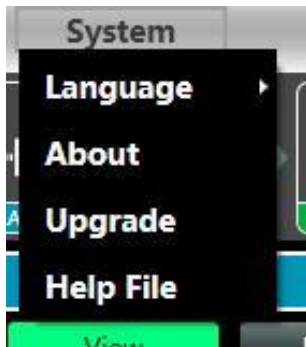

Language: multi-language switching, supports simplified, traditional, and ENGLISH.

About: current control software and device firmware version information.

Upgrade: use can upgrade the firmware by using this function, a upgrade *.bin* file should be needed from seller or speaker factory. In general, no need to upgrade the firmware in device. Only there is a bug or new function in software, upgrade function will be used.

4.10 FIR filter and function

4.10.1 FIR filter and applications

When user uses PEQ to adjust audio signal and set a linear magnitude, he can find the phase of signal changed, due to IIR filter. However, DSP products provide user a useful tool FIR filter to adjust audio signal with a linear phase.

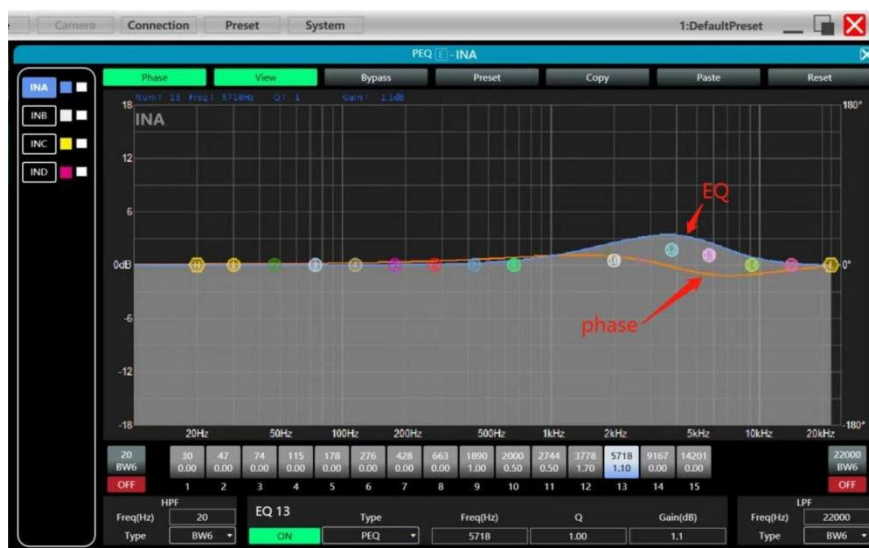

Some calculation:

Frequency resolution = Sampling/Taps

Available min. frequency \approx Frequency resolution*3

Means when use adjust audio signal with 48kHz, 1024 taps, FIR filters will take effect in frequency above 141Hz of audio signal. The taps value more high, the FIR filter curve more steep.

FIR filter processing audio signal will produce a certain delay:

Delay = (1/Sampling Hz)*Taps/2

Taps \ Sampling	48kHz	96kHz
256	2.67ms, LF 563Hz	1.33ms, LF 1125Hz
512	5.33ms, LF 279Hz	2.67ms, LF 558Hz
768	7.99ms, LF 188Hz	4.00ms, LF 375Hz
1024	10.67ms, LF 141Hz	5.33ms, LF 281Hz
2048	21.33ms, LF 70Hz	10.67ms, LF 141Hz

Applications:

- Linear of the phase curve of the speaker;
- Match the phase and magnitude of different speaker models within the same product line, as well as different speaker models in the installation project to make it easier to debug speaker groups and arrays;
- Dealing with linear array systems (for audience area coverage optimization);
- Frequency division optimization to improve the consistency of frequency response of multi-division speakers over their coverage Angle range.

Devices required:

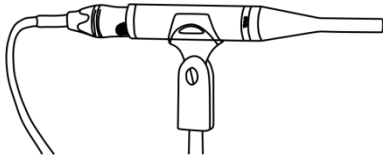
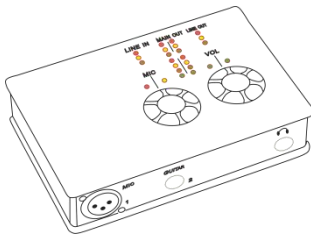
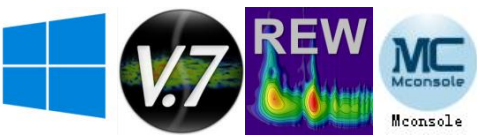
Measurement Microphone	×1	
Audio Interface	×1	
Windows PC (installed software including Smaart live or REW, and Mconsole)	×1	

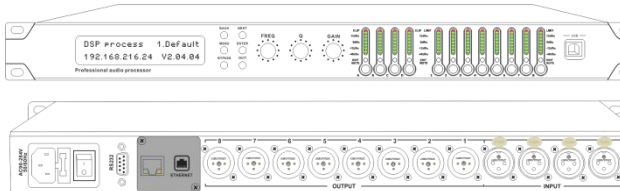
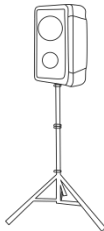
<p>FIR audio processor or DSP network power amplifier</p>	<p>×1</p>	
<p>Speaker</p>	<p>×1</p>	

Connection schematic diagram:

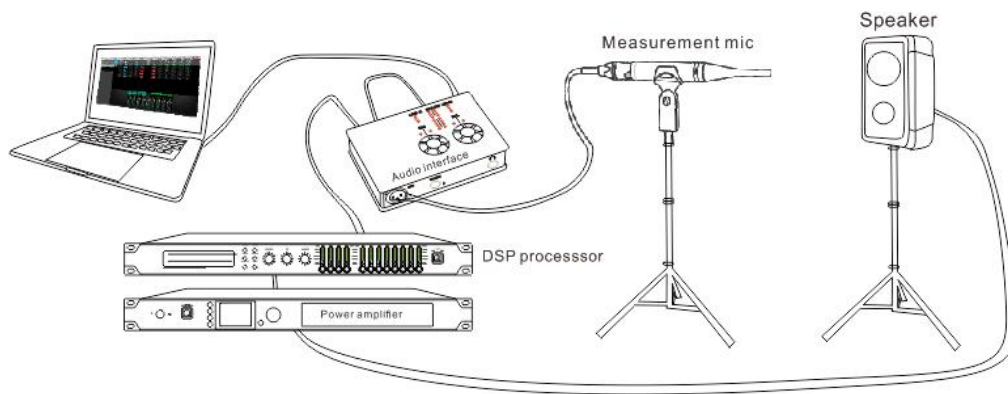

4.10.2 Using FIR DESIGNER in Mconsole to adjust FIR magnitude and phase

Beside using third party software, Mconsole provides user a more convenient way to adjust FIR magnitude and phase of each channels.

There are two ways to open FIR DESIGNER interface:

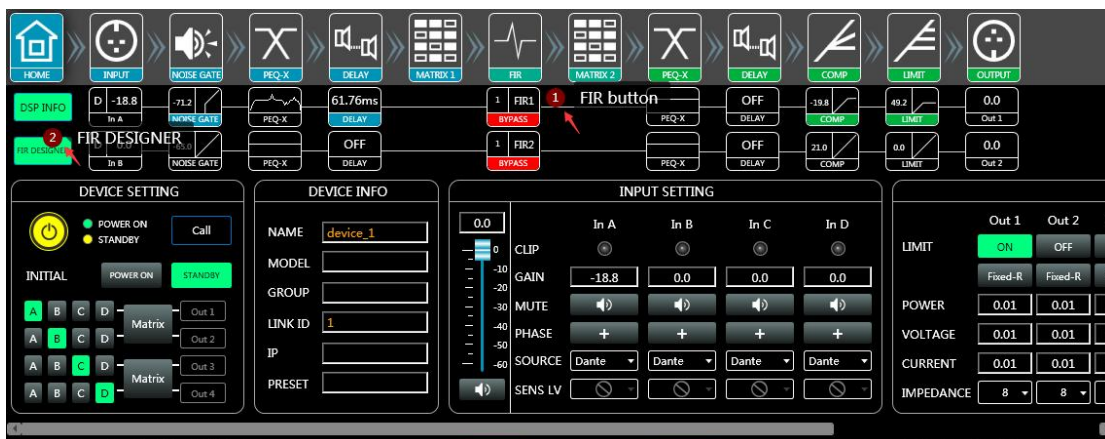



① Click “FIR” - “Designer” button to enter FIR automatic linear magnitude and phase function interface.

② Or click “FIR DESIGNER” in main interface to enter FIR automatic linear magnitude and phase function interface, which can quickly help user return to the page he set last time.

Let's begin to set:

4.10.2.a FIR DESIGNER - Import

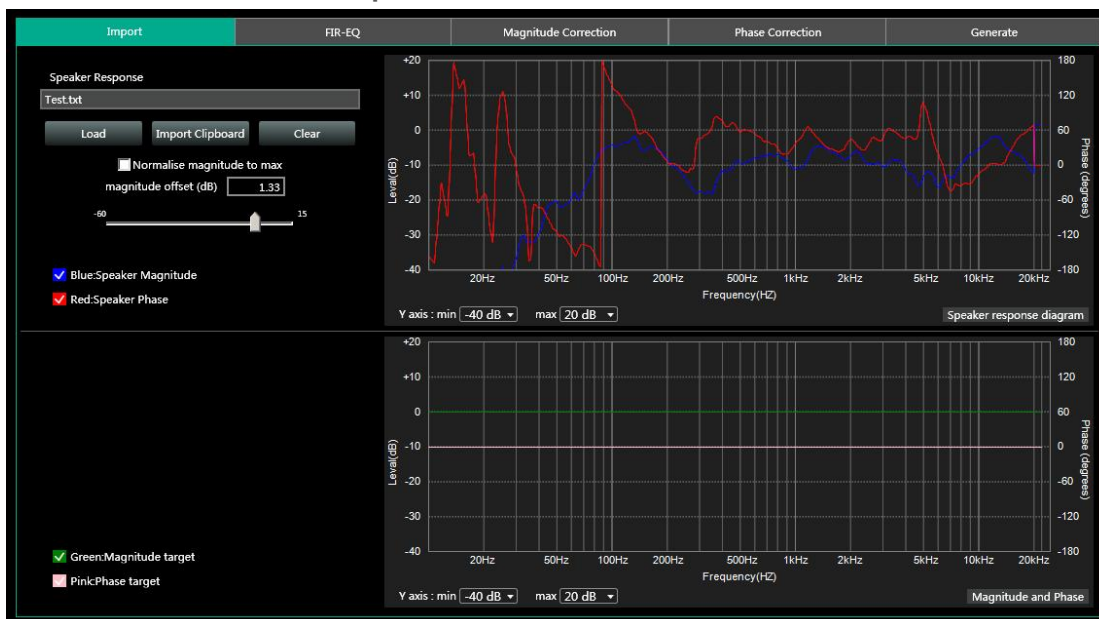

- **Load:** load speaker measurement file from Smart, usually it's a *.txt* file.
- **Import Clipboard:** load ASCII data directly from Smart.
- **Clear:** clear measurement data.
- **Normalise magnitude to max** or **Magnitude offset (dB):** this can help user to adjust a certain dB of magnitude, in order to adjust magnitude curve as little as possible.

4.10.2.b FIR DESIGNER - FIR-EQ

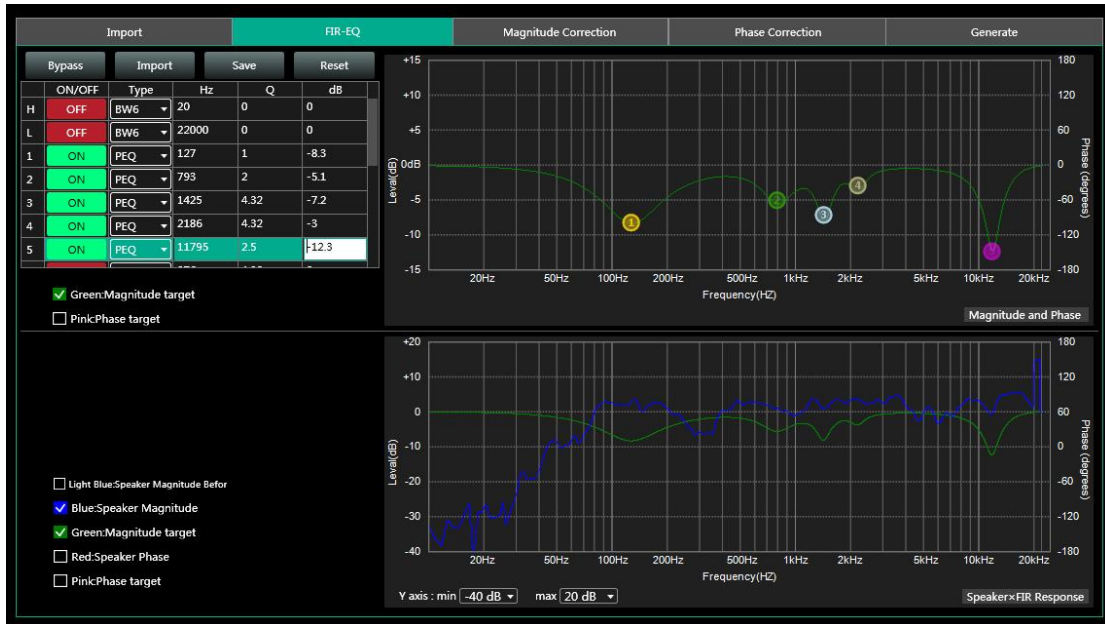

There are High pass filter and low pass filter for setting frequency divider, and 15 bands of PEQ \ LSLV \ HSLV to adjust magnitude. Try to set a linear magnitude of target speaker.
[Mark: changing FIR magnitude doesn't effect its phase.](#)

4.10.2.c FIR DESIGNER - Magnitude Correction and Phase Correction

Of course, if there are too many speakers to be adjust, user has to spend a long time manually adjusting their magnitude. In this case, Magnitude Correction will be more useful. Just enable **ON** button for frequency.



After adjusting magnitude, set linear phase of speaker.

NETWORK DSP POWER AMPLIFIER



4.10.2.d FIR DESIGNER - Generate

Select **Taps** (such as 512) of this adjustment, and store it in a FIR channel. User can also name this FIR adjustment and export it to a **.KF** file. After finish all setting, return back to FIR interface. Cancel **BYPASS** button to make it work.

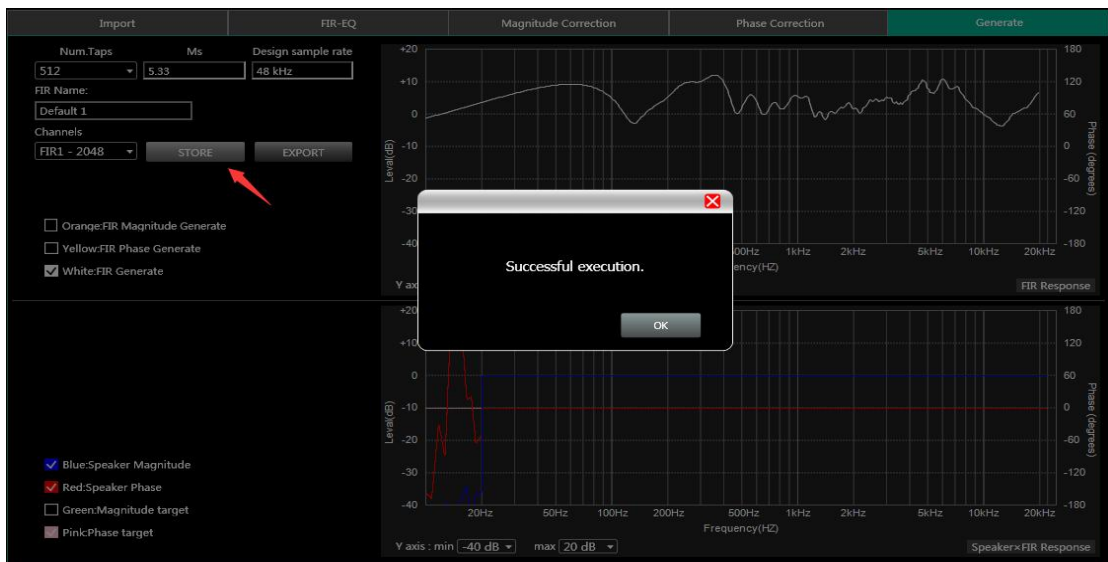

PD Series



PRO DG SYSTEMS INTERNATIONAL

P.I. Santa Bárbara. C/ Aceituneros nº 5.

41580 Casariche (Sevilla), Spain

Tel: +34 954 011 095

Cel: +34 678 548 947

export@prodgsystems.com

info@prodgsystems.com

www.prodgsystems.com